



QUICKDRAIN BENCHSEAT™ TECHNICAL SPECIFICATION

Job Name _____	Item # _____
Location _____	
Engineer _____	Contractor _____
PO # _____	Tag _____
Representative _____	

DESCRIPTION

The QuickDrain BenchSeat™ is made of extruded rigid PET (polyethylene terephthalate) plastic foam and is strong yet lightweight, non-reactive, economical, and shatterproof. The bench is chemically stable, UV resistant and suitable for both interior and exterior use. It shall be used in commercial or residential applications requiring a tileable seat for tiled showers. It can be used with both sheet and liquid topical waterproofing, eliminate the need for traditional mud bed installations, and can be assembled using thin set. It shall be lightweight, durable with high compressive strength 145 psi and can be quickly and easily modified to size and shape on-site. It shall be ready to assemble with no framing, mechanical fasteners, or anchors required. It shall be made of 100% recycled plastic and accommodate the ADA standards for height and exceeding the ADA weight guideline of 250 lbs.



APPLICATIONS/USES

- Industrial, commercial and residential showers
- Gang showers
- Pet Showers

SUITABLE SUBSTRATES (INTERIOR ONLY)

- Concrete
- Exterior Glue Plywood
- Cement backer board**
- OSB or Avantech

**Consult cement backer board manufacturer for specific installation recommendations

APPROVALS AND LISTINGS

Before installing QuickDrain USA system, check with your local building department/plumbing inspector to ensure compliance with the local building codes. QuickDrain USA LLC is not responsible for any conflicts with local building codes. QuickDrain USA LLC is not responsible for improper installation of any part of the assembly or the waterproofing membrane. Dimensions are subject to manufacturer's tolerance and can change without notice.

PRODUCT SELECTOR

✓	Product Number	Description
BENCH SEAT ONLY		
	QDTRIANGLE-SB	Large Triangular PET BenchSeat™
	QDTRIANGLESMALL-SB	Small Triangular PET BenchSeat™
	QDRECTANGLE-SB	Rectangle PET BenchSeat™

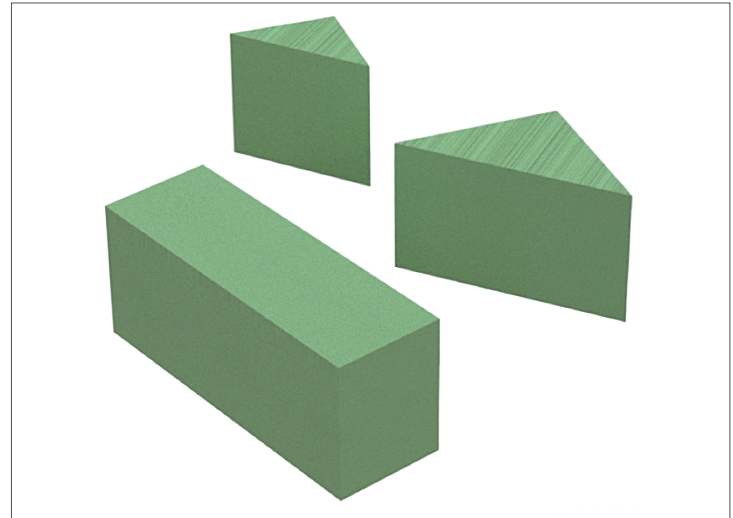

DIMENSIONS

SMALL TRIANGLE		
[A]:	Height	20"
[B]:	Width	16"
[C]:	Length	22-5/8"
[F]:	Material Thickness	2"
LARGE TRIANGLE		
[A]:	Height	20"
[B]:	Width	24"
[C]:	Length	34"
[F]:	Material Thickness	2"
RECTANGLE		
[A]:	Height	20"
[B]:	Width	16"
[C]:	Length	48"
[F]:	Material Thickness	2"

SMALL TRIANGLE

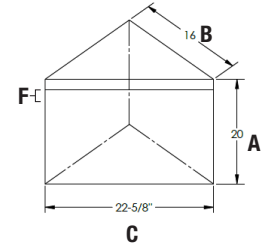

LARGE TRIANGLE

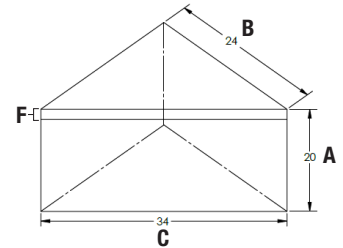

RECTANGLE

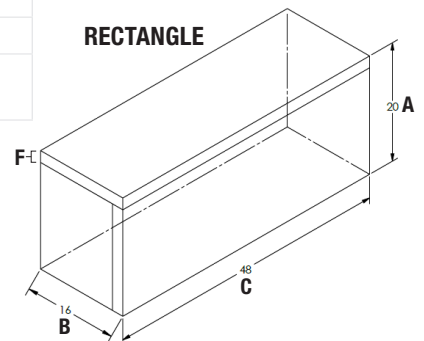

Access BIM/Revit content through www.quickdrainusa.com